

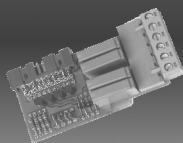

User's manual DH96 - BG

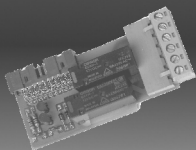

Chapter 1	Page
Product description	
Introduction	2-3
Technical specifications	4-5
Safety warnings	6
Chapter 2	
Installation and startup	
Dimensions	7
Wiring diagrams	8-9
Pluggin cards	10
Modification of the auxiliary voltage	11
Chapter 3	
Setting up the instrument	
Keyboard functions	12
Configuration introduction	13
Measurement configuration	14-15
Alarms configuration	16-17
Maximum current alarm configuration	18-19
Chapter 4	
Programmable digital panel instruments - DH96	20-21
DH96-P	
DH96-DC	
DH96-AC	
DH96-CPM	
Royal's serie: A1, A2, A3, A4, A5	

Digital indicator DH96-BG has been designed to offer a wide range of specifications and features in a compact and heavy duty device, thus allowing their operation within any industrial environment meeting all the requirements and standards currently established.

This equipment has been designed to control galvanic baths and to offer big range of characteristics.

This indicator is based on a microprocessor that regularly takes samples from the measuring signals by successive approximations from which it calculate voltage and current measurements. Nowadays this method is essential in order to guarantee a proper accuracy when monitoring distorting waves generally present at installations with a great quantity of industrial equipment that provoke an important distortion in the power system such as d.c. drives, rectifier units, electronic reactors, etc. Integrating current signal it get Amper/hour or Amper/minute. It have four counters where it accumulate A/h or A/min.

This equipment is also an ammeter and voltage meter because it can display those parameters.

The counter number one can be reset by the key, using external switch or applying external voltage (5 to 48 V)

The easy and intuitive setup process of digital indicators enables the user to quickly familiarize with their operation mode, for the modification of diverse configuration options with no need to consult this manual again.

Instruments of the DH96 Series have been tested in laboratories and checked in industrial environments, and have successfully passed the most rigorous tests involving ambient conditions, electrical noises, electromagnetic disturbances, mechanical vibrations, etc....

Expansion options

If we desired to control the process, it is possible to use an optional pluggable cards.

Available optional cards are:

- Cards equipped with two alarm relay outputs.
- Cards equipped with four alarm relay outputs.
-
- The instrument is equipped with a connector for the card input.

Each relay is associated to Amper/hour - minute counter.

It is possible select the reference value and alarm type: manual or automatic. When there is an alarm condition the relay will be energized. If the alarm is in manual mode it's necessary to press key  to will be unenergized. If the alarm is in automatic mode the relay will be energized the programmed time, after that the relay will be unenergized. In this mode the user can control it through the key, external switch (counter 1).

It is possible to associated the relay number 2 to current signal or to counter number 2, but not to both parameters. If the relay number 2 is associated to current signal, the user can select the maximum current reference and the delay (seconds).

NOTE: The external switch and external input voltage are to control counter number one.

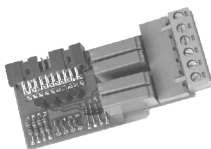
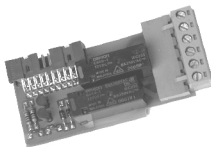

Auxiliary supply

Rated value:	115 V or 230 V (-15%, +20%)
Frequency range:	45 to 65 Hz
Burden:	4 VA (without optional card) 7 VA (maximun burden)

Display

0 ... 9999
7 segments
14 mm high 4 digits
Hi-efficacy red colour
Overrange indication: "----"
7 indication leds
Programmable decimal point
Data updating time on disp. <250ms

Input circuit

A/D converter resolution d.c.:	Meas. system by means of a microp. 13 bits (8192 points conv.)
Conversion method:	Successive approximations
Conversion time:	500 ms
Núm. of conversions per sample:	32
Measurement accuracy:	0,1% ± 1 digit
Current measurement range:	0...In
Voltage measurement range:	0...Un
Voltage overload:	1,5 Un contin. / 3 Un during 10 s
Current overload:	2 In continuously / 5 In during 5 s
Voltage burden:	0,001 VA
Current burden:	0,003 VA

Isolation

Test voltage:	3 kV RMS 50 Hz during 1 min
Pulse test:	4 kV (1.2 / 50 ms)

Between the input circuit, the measuring circuit and the output relays.

Environmental conditions

Storage temperature:	-40 °C ... + 70 °C
Operation temperature:	-10 °C ... + 65 °C:

Relays characteristics **1 commuted contact**

Rated a.c. current:	8 A
Maximun a.c. current:	10 A
Rated voltage:	250 V a.c. 50 Hz
Maximun voltage (VDE 0435):	440 V a.c.
Maximun a.c. resistive load:	2000 VA
Isolation resistance at 500V:	> 10 ⁴ MW
Contact-coil isolation:	6000 V a.c.
Contact-contact isolation:	1000 V a.c.
Mechanical endurance:	> 20 x 10 ⁶ operations
Electrical endurance:	> 2 x 10 ⁶ operations at 5A and 35V

Relays characteristics **1 single contact**

Rated a.c. current:	5 A
Maximun a.c. current:	5 A
Rated voltage:	250 V a.c.. 50 Hz
Isolation resistance at 500V:	> 1000 MW
Contact-coil isolation:	2000 V a.c.. - 1 min
Contact-contact isolation:	1000 V a.c. - 1 min
Mechanical endurance:	> 20 x 10 ⁶ operations
Electrical endurance:	> 100 x 10 ³ operations

General characteristics

Dimensions:	96 x 48 x 138 mm
Weight:	550 g
Case material:	Self-exting. ABS, anthracite grey
Protection degree:	Frontal: IP54 IP65 with frontal protect.
	Case: IP20
	Terminal: IP20

Desing standards

IEC 1010 / IEC 348 / IEC 664
IEC 801 / VDE 0110 / VDE 0435
EN 50081-2 / EN 50082-2

17.3 Information and warning texts

The DH96 meets protection class I.

- . All indicators are equipped with a grounding terminal
- . The case is not dangerous to tactile touching (isolating material)
- . Screws of terminals are not accessible for human appendix

This instrument has been designed and tested to meet IEC 348 standard and is factory-shaped in proper conditions. The manual you hold in your hands contains information and warnings that the user should respect in order to guarantee a proper operation of all instrument's functions and keep its safety conditions.

17.3.2 Installation

The instrument is for indoor use. It could be occasionally subjected to temperatures between +75 °C and 10 °C keeping its safety conditions.

The instrument must not be powered and used until to be correctly assembly on the board. Before powering the instrument, its grounding terminal must be connected to a suitable protection conductor.

17.3.4 Warning!

Any interruption of the protection conductor, either inside or outside the instrument, or the disconnection of the protection grounding terminal might imply a dangerous situation; therefore, any intentional interruption is totally forbidden.

17.3.5 Adjustment, element replacement and repairing actions

With the instrument powered on, the terminals could be dangerous to touch and cover opening actions may allow accessing dangerous parts. Therefore, before any adjustment, replacement, maintenance or repairing operation is carried out, the instrument must be disconnected from any power supply source.

No adjustment, maintenance or repairing operation should be done over the instrument open and powered and, should those are essential, high-qualified operators must perform them.

Check that fuses used for replacing damaged ones match required types and rated currents. The use of improvised fuses or to short-circuit fuse bases is totally avoided.

17.3.6 Defects and malfunction

When any protection failure is suspected to exist, the instrument must be immediately put out of service. The protection could be damaged whether:

- . You can see damages on the case
- . It cannot perform proper measurements
- . Storage conditions were not the suitable ones
- . Any damage in transit occurred.

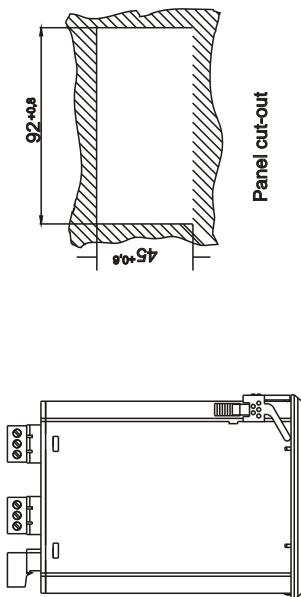
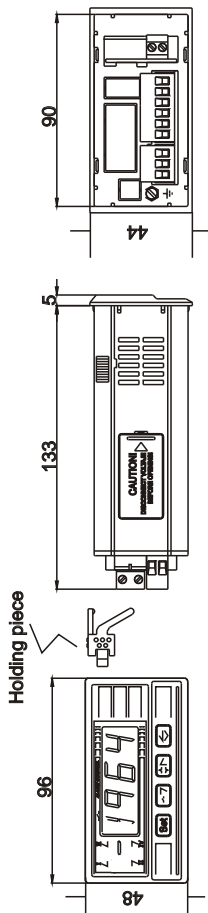

To Positive Shunt connection.

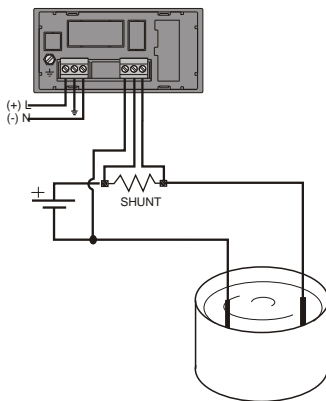

To Negative Shunt connection.

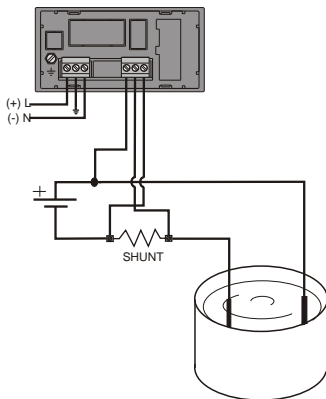

Optional cardss

2 Relays

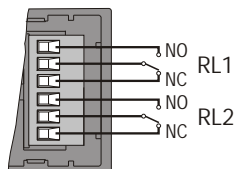

4 Relays

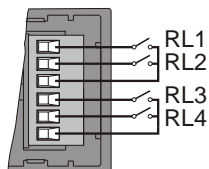

Remote control

External switch

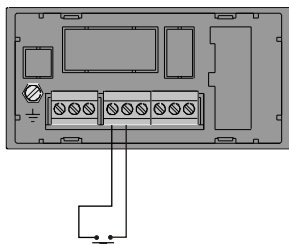

Voltage input

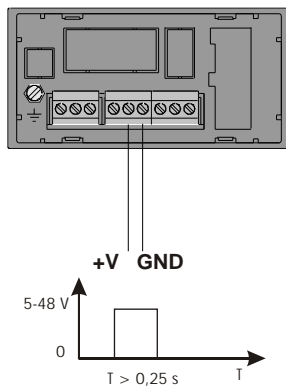

Plugging cards

WARNING: Insure that no incoming wire is connected to the instrument before doing any work on the equipment, since failure to observe this practice can result in equipment damage and even serious injury.

Proceed as below pictures show.

1) Press the case holding piece with a screwdriver or a similar tool in order to release the base from the rest of the case.

2) Remove the set composed by the base and circuits by pulling the base and carefully sliding it out.

3) Insert the card into the appropriate connector . Take care that only the connector is press but not all the card.

4) Put the set composed by the base and circuits in again by pushing the base and carefully sliding it into. When the set is totally inserted, press until the case holding pieces are fitted into the pertinent holes.

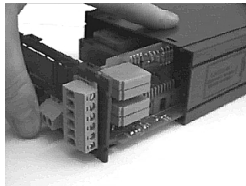
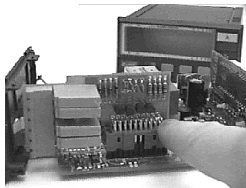
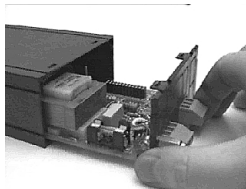
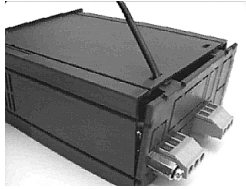

Instrument is manufactured to be energized at 230 V a.c., But it is possible to change to 115 V a.c. Following the instructions below mentioned.

To perform this modification, open the instrument case (see page 9, "Plugging cards"), thoughtfully following all safety warnings (see section 17.3.5 at page 6), and identify the zone referred in the figure 1.

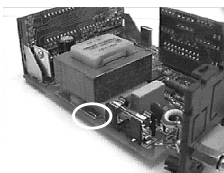

For an auxiliary supply of 230 V only the jump labeled as 1 must be done (figure 2).

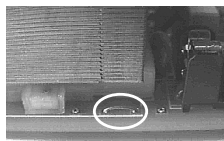

On an auxiliary supply of 115 V is required, only jumps labeled as 2 and 3 must be done (figure 3).

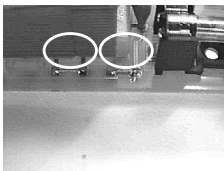

Setup option



Pressing this key, setup menus are accessed for user-configuration actions. Once within the setup menus, use this key to validate the options and modifications.

Default setup values



Pressing this key during at least 5 s, default setup values replace user-configured ones.

Alarms







(Only when any alarm card is inserted)

Pressing this key, alarm conditions can be visualized and modified.

Pressing the button once the alarm 1 condition is shown up on display and it could be modified if required.

If CE option is "Enable", it is possible modify its value.

If any value is modified, press  and  to enter the new value and then press  to validate this change.

The process to introduce a new value, begin introducing the new value, press  to validate. After it is necessary to situate the decimal point and to finish indicate if the value is kA/h-m or A/h-m.

Password





Pressing simultaneously both keys when the instrument is powered on, a 4 digit password can be set in order to control the access configuration options. To disable this password, reset the instrument and simultaneously press again both keys when powering it. Enter the set password and menu will be accessible again.

Note: The password must be always entered twice, the first one to define it and the second one to confirm it. In case that the confirmation does not match with the first defined password, instrument will continue its initialization process.

Amper/hout-min Counters



To reset the counter, it will be necessary to press  key during 3 seconds while counter is displaying. The counter num  can be reset with external switch or with external voltage (5 to 48 Vd.c.).

Display



To see all the parameters it is necessary to press  key repeatedly.

DH96-BG configuration can be carried out easily and intuitively by using a tree-type menu.

Steps to be followed are:

1) First of all, you have to select external shunt value which is connected to the equipment to measure current signal. At this stage is necessary to enter the value and decimal point position.

2) Then, define the most appropriate integration unit: hour or minute.

3) The equipment have 4 configurables alarms. Every alarm is associated to counter (A/h or A/m). If the equipment doesn't have relays card, it is possible to program the alarms and have a visual led to indicate its state.

To program the alarm is necessary to proceed as follows:

A) Select reference value. When A/time counter exceed this value there will be an alarm condition.

It is necessary to follow next three steps to introduce new alarm value. First you should enter numeric value (4 digits value). After that decimal point has to be positioned. To finish you should choose counter's unit (kA/h-m or A/h-m)

B) Select control mode: manual or automatic. If manual mode is selected, when there is an alarm condition the user must reset the counter manually. If automatic mode is selected, it's necessary program the time in seconds. When this time has passed, the counter will automatically reset.

Configuration

Setting up the instrument

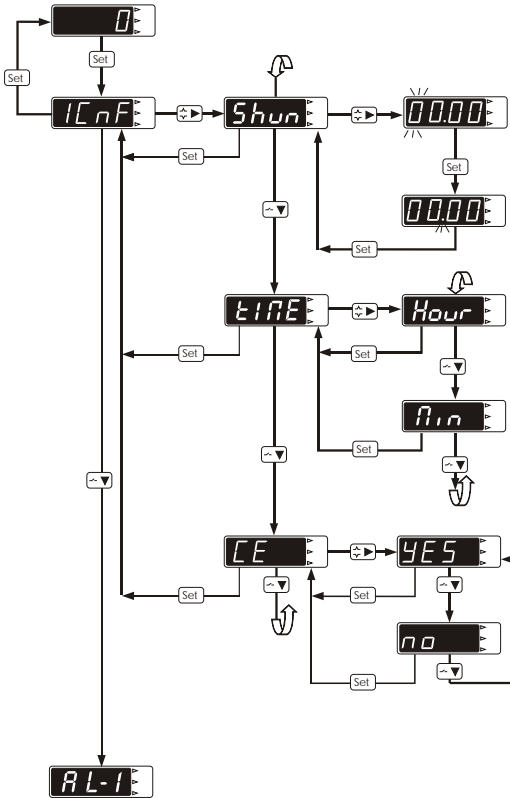



Input

Set here the pertinent current input (.../60 mV). First of all, select a numerical value. Then, define the decimal point position.



Integration unit

It is necessary to select the integration unit: hour or minute.



Configuration enabled

Set at (NO) avoids any modification of the above parameters. Set at (YES) it enables their modification..

Setting a value

To cyclically move along the four digits, press the key

To modify the value of the selected digit repeatedly, press the key

Set the desired 4 digits value using both above keys.

NOTES:

If no parameter is allowed to be modified, go to the last display (CE) and check whether this is set at YES, otherwise change it.

To validate all modifications done over the instrument setup press the key repeatedly until measuring mode is again accessed.

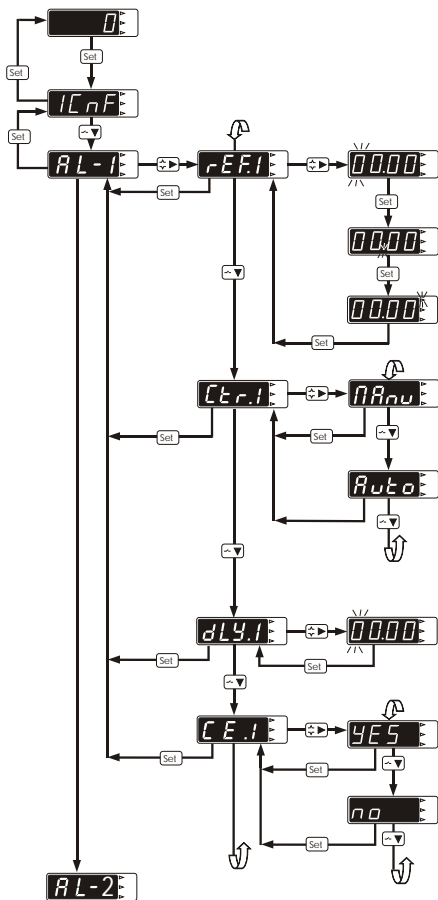



Reference Value

Set here the alarm value reference. First introduce numerical value. Then, define the decimal point position with key and to finish, select the multiplier (x1000) lighting kA or (x1).



Control type

To select the control: automatic or manual. If the control is manual, the relay is energized when there is an alarm condition. To unenergized the relay, the user must display the alarm counter and press the key . The counter number 1 can be reset through an external switch or input voltage (5 to 48 Vdc). If the automatic control is selected it is necessary to introduce the delay time as long as the relay is energized. Afterwards the counter will be reset, unenergizing the relay.



Delay

Set here the delay time in seconds when the automatic control is selected.



Configuration enabled

Set at (NO) avoids any modification of the above parameters. Set at (YES) enables their modification.



Input

Set here the input alarm type. First, select if the alarm number 2 is associated to current, or to counter number 2. If the alarm is referenced to instant current this relay is an alarm of maximum current.



Reference value

Set here the current reference if the measurement selected is the current. When the signal current exceed these level the relay number 2 will be energized.



Delay

It is possible to program the delay in seconds. When the current signal exceed the reference value, the relay will not energize until the delay has finished



Configuration enabled

Set at (No) avoids any modification of the above parameters. Set at (Yes) enables their modification.

Digital serie's

DH 96

- Fully programmable.
- High performance.
- Easy to use.
- Strong desing.



Presents full range of digital panel instruments with high performance.

- 2 relay card.
- 4 relay card.
- Analog output card.
- RS232 - Rs485 communications.

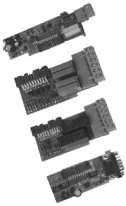

- Royal A1-P *Voltage, current and frequency measurement*
- Royal A2-P *Three current measurement*
- Royal A3-P *Three voltage measurement*
- Royal A4-P *Single phase or three phase system measurement*
- Royal A5-P *Three current measurement for engines protection*
- DH96 D.C. --- *Programmable digital meter d.c.*
- DH96 A.C. \approx *Programmable digital meter a.c.*
- DH96 B.G. *Digital meters for galvanic baths (A/hour - A/minute)*
- DH96 CPM *D.C. Measurement parameters*

SELECTION GUIDE

	DH96 D.C.	DH96 A.C.	DH96 BG.	DH96 CPM	ROYAL A1	ROYAL A2	ROYAL A3	ROYAL A4	ROYAL A5
V D.C.	X			X					
A D.C.	X			X					
V A.C. ^{TRUE} _{RMS}		X			X			X	
A A.C. ^{TRUE} _{RMS}		X							
Hz					X				
W ⁴ _{QUADRANTS}									
Var ⁴ _{QUADRANTS}									
VA ⁴ _{QUADRANTS}									
PF ⁴ _{QUADRANTS}									
Distortion factor $\mu d''$									
Max. demand in A									
Max. demand in W									
3-V.A.C. ^{TRUE} _{RMS}							X		
3-A.A.C. ^{TRUE} _{RMS}						X		X	
UNBALANCED CURRENT									
Amps / h Amps / min			X						
KW - KW/h				X					

OPTIONAL CARDS

	DH96 D.C.	DH96 A.C.	DH96 BG.	Dh96 CPM
2 RELAYS	X	X	X	X
4 RELAYS	X	X	X	X
ANALOG OUTPUT	X	X		X
RS-485 OUTPUT	X	X		X
RS-232 OUTPUT	X	X		X

NOTE:
Equipment's serie ROYAL have included 2 relays with commuted contact.