

Current and time based switch

Temperature limiter

Thermostat

A

10

20

30

40

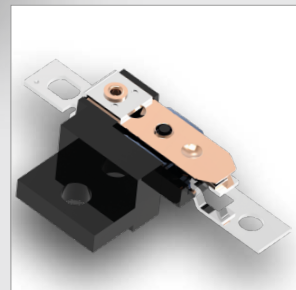
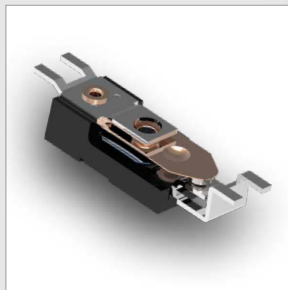
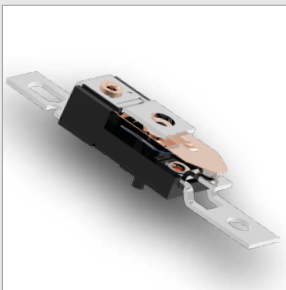
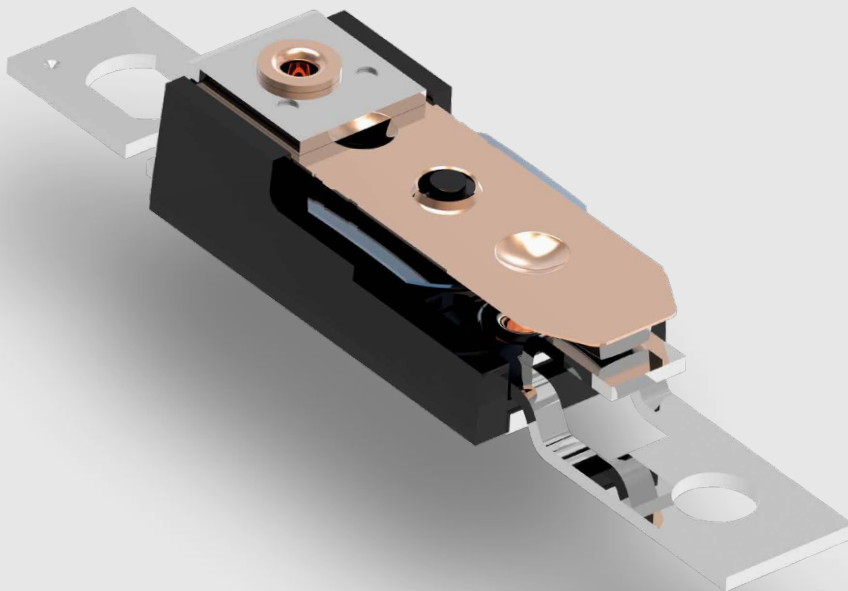

Applications

- Household appliances
- Electronics
- Fan heaters
- Automotive industry

Benefits

- Highest safety by self hold types
- PCB terminals available
- Customized ratings
- Manual reset

Description

Series A switches are based on a **complex system consisting of a contact spring unit and a thermo-bimetal snap-disc**. When heating up to the fixed switching point, the contact opens and thus interrupts the power circuit.

They are very flexible to use: Due to the different types of reset and the adjustable current sensitivity for quick shutdowns, the A switches offer **high quality solutions**, especially in very specific safety concepts.

Temperature switch with **automatic reset A10**: After a certain cooling phase (temp. hysteresis) the contact switches back automatically.

Temperature limiter with **manual reset A20**: After opening the contacts and the subsequent cooling the contacts remain open until a manual reset is performed on the reset pin.

Temperature switch with **electr. self-hold A30 (230V) / A40 (120V)**: After opening the contacts the switch is heated by a parallel connected resistor and thus kept open. The automatic reset is only performed through a mains disconnection, or off-switching of the device in which the temperature switch is installed.



Technical data

type ratings		control			
		A10V A11V	A20V A21V	A30V A31V	A40V A41V
function		automatic	manual	self hold 230 V	self hold 120 V
version		normally closed			
VDE	rated current at 50 / 60 Hz (power factor 0.95 / 0.6)	16 A / 2.5 A (250 V)	16 A / 2.5 A (250 V)	16 A / 2.5 A (230 V)	19.2 A / 2.5 A (120 V)
	switching cycles	10,000	1,000	10,000	8,000
	temperature range T _A (steps in 5 °C)	70 °C ... 160 °C	70 °C ... 130°C / 140 °C	70 °C ... 160 °C	
UL	rated current at 50 / 60 Hz (power factor 1.0 / 0.75)	16 A / 6.3 A (250 V)			16 A / - (125 V)
	switching cycles	6,000			
	temperature range T _A (steps in 5 °C)	70 °C ... 160 °C			
max. current at 250 V 50/60Hz (power factor 0.95)		25 A			
switching cycles under max. current		200			
tolerance		standard: ± 5 °C			
feature of automatic action		1.B, 2.B	2.B	2.C.AK	
contact resistance		< 50 mΩ			
hysteresis / reset temperature ¹⁾		30 °C ± 15 °C / -	- / < -20 °C ; < -10 °C	- / < -20 °C ²⁾	
suitable for use in protection class		I, II			
approvals	VDE / ENEC		EN 60730-1 / -2-9		
	UL		UL 873		
	CSA		C22.2 No. 24 ³⁾		
	CQC		GB14536.1-1998 / GB14536.10-1996 ⁴⁾		

¹⁾ at the T_A (upper and lower) limits the hysteresis could deviate ²⁾ without air flow ³⁾ different power rating ⁴⁾ details on request

For special applications version P is available with a very low self heating rate.

Manual reset: The maximum operating force must not exceed 6 N. The control should not be reset before the starting conditions are reached, meaning there should be a satisfactory cooling down time!

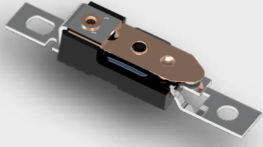
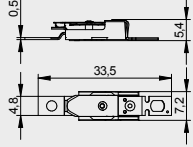
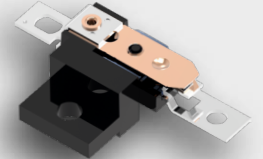
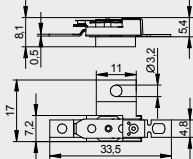
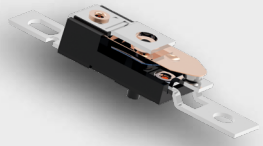
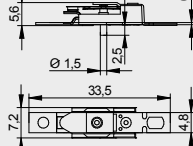
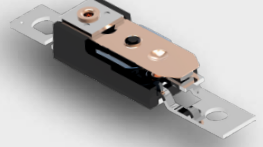
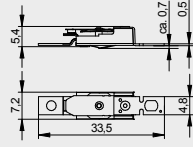

Technical data on request.

Versions

TCO		illustration	drawing dimensions (mm)	technical specification	approvals
standard	current - time based ¹⁾				
A10V	A12V			base of thermosetting plastic	VDE, UL, CSA
A11V A21V A31V A41V	A13V A23V A33V A43V			screw-on fixing base of thermosetting plastic	VDE, UL, CSA
A20V	A22V			manual reset base of thermosetting plastic possible screw-on fixing dimensions see above	VDE, UL, CSA
A30V A40V	A32V A42V			voltage maintained PTC 120V or 230V base of thermosetting plastic possible screw-on fixing dimensions see above	VDE, UL, CSA

¹⁾ For current-time based types (execution D, J, K, L, M, P, R, V) the following information must be provided:

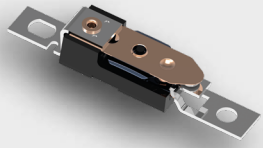
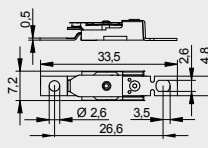
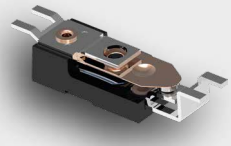
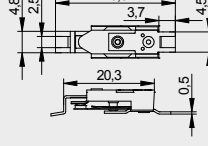
- GDC or AC voltage U_N in Volts.
- Continuous operating current I_C in Amps at which the switch must not respond.
- Current level I_0 in Amps at which the switch must respond and the response time t_0 (in seconds \pm tolerance).
- Ambient temperatures which could be experienced both in normal operation and in switching conditions.
- Maximum current in Amps.

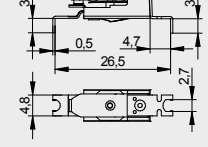
code	used in TCO	illustration	drawing dimensions (mm)	technical specification	approvals
standard	A10, A11, A12, A13 A20, A21, A22, A23 A30, A31, A32, A33 A40, A41, A42, A43			terminals for soldering, screwing, riveting or welding- CuNi18Zn20 ¹⁾	VDE, UL, CSA
A321	A10, A12 A20, A22 A30, A32 A40, A42			SMD terminals CuNi18Zn20 ¹⁾	VDE, UL
A322	A10, A12 A20, A22 A30, A32 A40, A42			THT terminals CuNi18Zn20 ¹⁾ Anschlüsse CuNi18Zn20 ¹⁾	VDE, UL

¹⁾ P types have terminals of CuFe2P material

Current vs. self heating

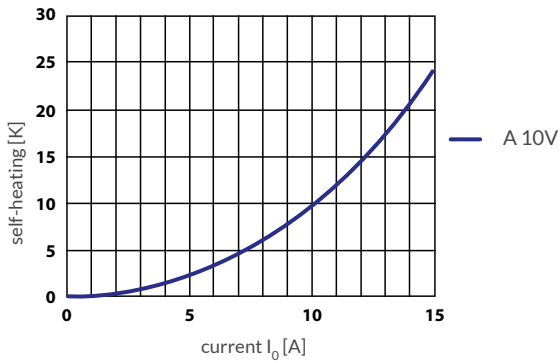

Test conditions:
Measurement in air flow and lead wires of 1.5 mm².

Current vs. response time

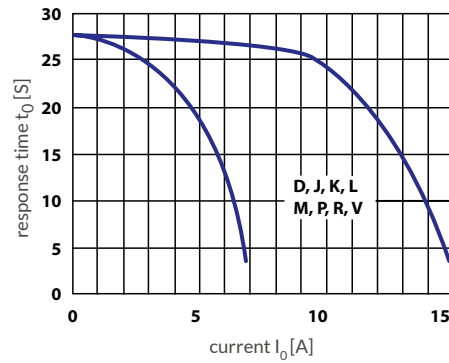

TCO variations for current-time based applications.

Ordering example

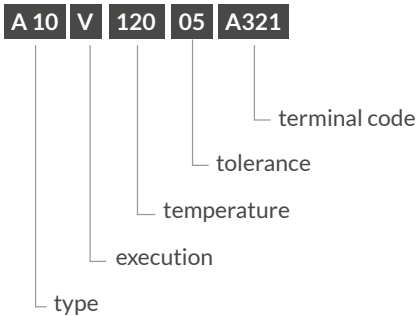

Marking

- A10V** type and execution
- D** country (D=Germany)
- 12005** response temperature (120°C), tolerance ($\pm 5^\circ\text{C}$)
- 057** date of manufacture (May 2017)
- A12D** type and execution
- H** country (H=China)
- 123** customized type with drawing number
- 057** date of manufacture (May 2017)

Microtherm Sentronic GmbH

Taschenwaldstraße 3
75181 Pforzheim
Deutschland
Tel.: +49 7231 787-0
Fax: +49 7231 787-155
info@microtherm.de
www.microtherm.de



MICROTHERM
sentronic