

Thermal cut-out

Thermal fuse

Typ

HDM

MT

SDF

S3M

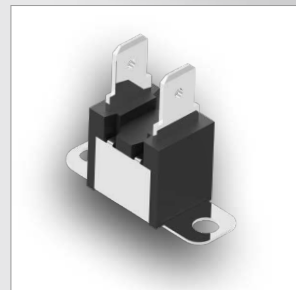
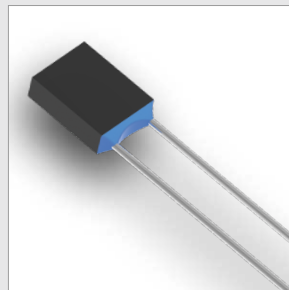
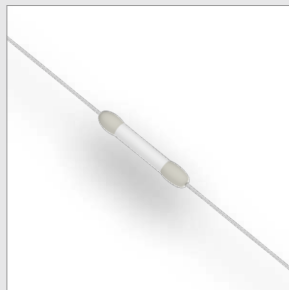
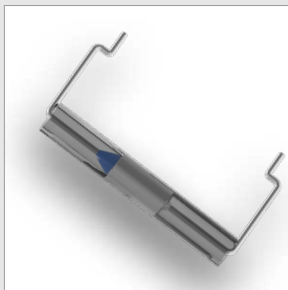
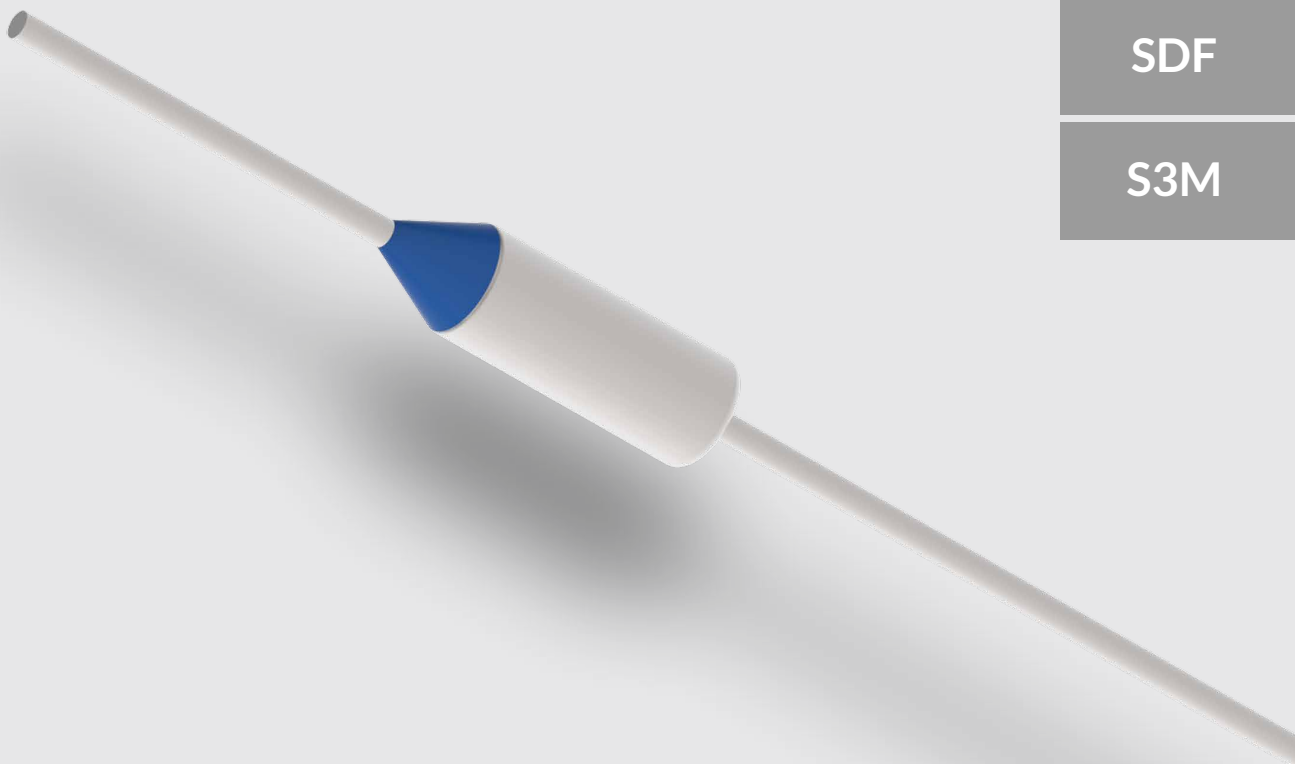

Applications

- Household appliances
- Electronic appliances
- Fan heaters
- Transformers
- Automotive industry

Benefits

- Small compact designs
- Broad product line
- Temperature range up to 240°C
- Custom-made executions

Description

Fuses of this type are highly universally applicable due to their small design and the **wide range of current-carrying capacity**. They are found in all industries with electro-technical applications.

The portfolio ranges from the **miniature fuse S3M7** with a \varnothing 3 mm and length of 10 mm, up to the **robust S3M8** with a current load capacity of up to 25 A. And the so-called high-current fuses S3M5 and S3M8 can be particularly found in heating applications of all kinds.

Since the purely wired fuse body usually has to be further processed for the respective application (insulation of the body, integration of connecting leads and connectors), Microtherm also offers the **possibility of customer-specific designs** for these fuses.

Beside these Microtherm offers the **MT series** in axial and radial shape as a cost-effective solution for a wide range of applications. These thermal fuses are based on melting wire design whereas technical data is given in the tables on the right page.

The portfolio of thermal fuses is fulfilled by the **HDM series** which is a robust surface mounting device.

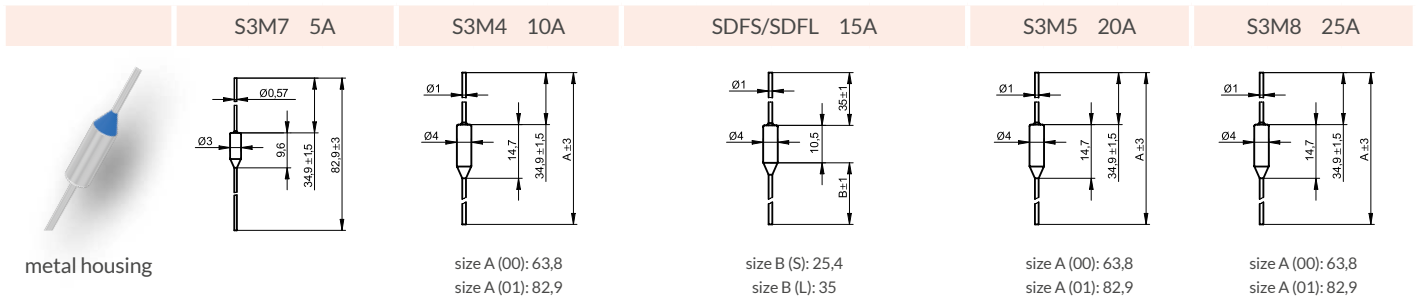

T_f (tolerance +0/-10°C)	type	T_h	T_m	type	T_h	T_m	type	T_h	T_m (VDE)	T_m (UL)	type	T_h	T_m	type	T_h	T_m
66	-	-	-	-	-	-	DF	42	110	130	-	-	-	-	-	-
70	E7F	55	125	E4A	55	130	-	-	-	-	E5A	55	175	E8A	45	175
72	-	-	-	E4A	57	100	DF	50	115	110	E5A	57	175	E8A	47	175
77	E7F	62	125	E4A	62	125	DF	55	120	110	E5A	62	200	E8A	52	200
84	E7F	69	125	E4A	69	125	DF	60	125	114	E5A	69	200	E8A	59	200
91	-	-	-	-	-	-	DF	57	135	121	-	-	-	-	-	-
93	E7F	78	140	E4A	78	140	-	-	-	-	E5A	78	215	E8A	68	215
98	E7F	83	140	E4A	83	140	DF	76	140	130	E5A	83	215	E8A	73	215
100	E7F	85	130	E4A	85	140	DF	78	135	250	E5A	85	215	-	-	-
104	-	-	-	E4A	89	150	DF	80	150	150	E5A	89	225	E8A	79	225
110	E7F	95	140	E4A	95	150	DF	88	140	140	E5A	95	225	E8A	85	225
117	E7F	102	150	E4A	102	160	-	-	-	-	E5A	102	235	E8A	92	235
119	-	-	-	-	-	-	DF	95	170	170	-	-	-	-	-	-
121	E7F	106	150	E4A	106	160	-	-	-	-	E5A	106	235	E8A	96	235
128	E7F	113	150	E4A	113	205	DF	106	155	155	E5A	113	235	E8A	103	235
141	-	-	-	-	-	-	DF	117	171	171	-	-	-	-	-	-
144	E7F	129	175	E4A	129	240	DF	120	250	250	E5A	129	250	E8A	119	250
152	E7F	137	175	E4A	137	205	DF	128	176	175	E5A	137	250	E8A	127	250
167	E7F	152	200	E4A	154	240	-	-	-	-	E5A	152	285	E8A	142	285
170	-	-	-	-	-	-	DF	146	300	190	-	-	-	-	-	-
172	E7F	157	200	E4A	157	240	-	-	-	-	E5A	157	350	-	-	-
184	E7F	169	200	E4A	169	210	DF	160	300	214	E5A	169	350	E8A	159	350
190	E7F	175	270	E4A	175	310	-	-	-	-	E5A	175	350	-	-	-
192	-	-	-	E4A	177	210	DF	164	290	222	E5A	177	350	E8A	167	350
205	-	-	-	E4A	189	310	-	-	-	-	E5A	189	375	-	-	-
216	-	-	-	E4A	200	375	DF ¹⁾	191	241	-	E5A	200	375	-	-	-
228	-	-	-	-	-	-	DF	193	300	300	-	-	-	-	-	-
229	-	-	-	E4A	200	375	-	-	-	-	E5A	200	375	E8A	200	375
240	-	-	-	E4A	200	450	DF	200	290	260	E5A	200	375	E8A	200	375

¹⁾ VDE approved only Tape + Reel, cut and bent on request

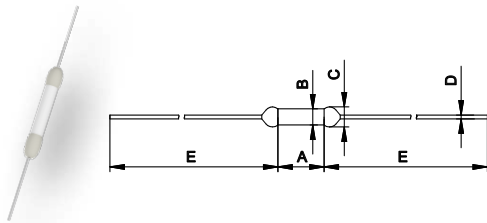

type	A	B	C	D	E	approvals
MTVS	6,5±0,5	Ø2,1±0,1	2,6 max	Ø0,5±0,05	37±3	UL, cUL, TÜV, CCC
MTKF	6,0±1	Ø1,5±0,1	1,8 max	Ø0,53±0,1	'00' = 38±3; '01' = 68±3	UL, VDE
MTHS	9,0±0,5	Ø2,5±0,5	3,0 max	Ø0,54±0,05	36±3	UL, cUL, TÜV, CCC
MTTF	6,3±1	Ø2,0±0,1	2,3 max	Ø0,53±0,1	'00' = 38±3; '01' = 68±3	UL, VDE
MTCS	11,5±0,5	Ø3,3±0,5	3,8 max	Ø0,80±0,05	35±3	UL, cUL, TÜV, CCC
MTYF	10,0±1	Ø3,0±0,2	3,3 max	Ø0,70±0,1	'00' = 38±3; '01' = 68±3	UL, VDE

T _f (tolerance +0/-10°C)	type 1A	T _h	T _m	type 2A	T _h	T _m	type 5A	T _h	T _m
76	MTVS - V0 ¹⁾	53	200	MTTF - TOF ²⁾	55	200	MTCS - C0 ¹⁾	53	200
86	MTKF - K1F	60	200	MTTF - T1F ²⁾	60	200	MTCS - C18	61	200
102	MTKF - K2F	80	200	MTTF - T2F	75	200	MTYF - Y2F	70	200
115	MTKF - K3F	99	200	MTTF - T3F	95	200	MTYF - Y3F	90	200
127	MTKF - K4F	110	200	MTTF - T4F	110	200	MTYF - Y4F	100	200
133	MTKF - K13F	110	200	MTHS - H8	111	200	MTCS - C8	108	200
136	MTKF - K5F	115	200	MTHS - H9	112	200	MTCS - C9	111	200
139	MTVS - V13	115	200	MTHS - H13	115	200	MTCS - C13	112	200
145	MTVS - V6	121	200	MTTF - T7F ²⁾	125	200	MTCS - C6	118	200
150	MTVS - V7	126	200	MTHS - H7	126	200	MTCS - C7	123	200

¹⁾ only TÜV, CCC ²⁾ only 1A

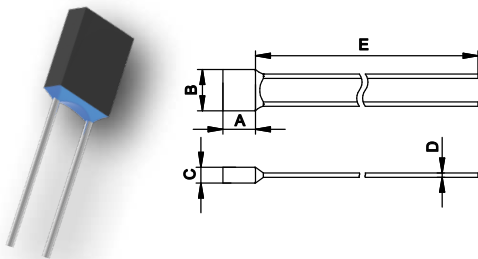

type	A	B	C	D	E	approvals
MTNF	4,1±0,5	5,2±0,5	2,0±0,3	0,53±0,1	'S' = 36±3; 'L' = 68±3	UL, VDE
MTF	4,1±0,5	5,2±0,5	2,3±0,2	0,50±0,05	56±3	UL, VDE, CCC
MTX	5,8±0,5	5,8±0,5	2,3±0,2	0,54±0,05	64±3	UL, VDE, CCC
MTY	7,0±0,5	6,6±0,5	2,7±0,3	0,80±0,05	63±3	UL, VDE, CCC
MTT	7,5±0,5	8,3±0,5	3,4±0,2	1,05±0,5	38±5	UL, VDE, CCC
MTP	11,5±0,5	10,8±0,5	4,8±0,2	1,60±0,05	39±5	UL, VDE, CCC

T _f (tolerance +0/-10°C)	type 1A	T _h	T _m	type 3A	T _h	T _m	type 5A	T _h	T _m	type 15A	T _h	T _m	type 20A	T _h	T _m
76	MTF - F0 ¹⁾	53	200	MTX - X0 ¹⁾	53	200	MTY - Y0 ¹⁾	53	200	-	-	-	-	-	-
86	MTNF - N1F	60	200	MTX - X18	61	200	MTY - Y18 ¹⁾	61	200	-	-	-	-	-	-
102	MTNF - N2F	75	200	MTX - X1	79	200	MTY - Y1 ¹⁾	77	200	MTT - T102	72	200	-	-	-
115	MTF - F2	91	200	MTX - X2	91	200	MTY - Y2	89	200	MTT - T115	85	200	MTP - P115	82	200
125	MTF - F3	100	200	MTX - X3 ³⁾	100	200	-	-	-	-	-	-	-	-	-
130	MTF - F4	106	200	MTX - X4	106	200	MTY - Y4	103	200	-	-	-	-	-	-
133	MTF - F8	111	200	MTX - X8	111	200	-	-	-	-	-	-	-	-	-
136	MTNF - N5F	100	200	MTX - X9	112	200	MTY - Y9	111	200	MTT - T136	106	200	MTP - P136	102	200
145	MTF - F6 ¹⁾	121	200	MTX - X6	121	200	-	-	-	-	-	-	-	-	-
150	MTF - F7	126	200	MTX - X7	126	200	MTY - Y7	123	200	-	-	-	-	-	-
160	MTF - F16 ²⁾	135	200	MTX - X16 ²⁾	135	200	-	-	-	-	-	-	-	-	-

¹⁾ not VDE ²⁾ only CCC

T _f	Rated Functioning Temperature: The maximum temperature at which the thermal cutoff changes its state of conductivity to open circuit with sensing current as the only load. The rated functioning temperature is measured during a temperature rise of approximately 0.5°C per minute.
T _h	Holding Temperature: Maximum temperature of the TCO measured at the case end of the thermal cutoff at which the thermal cutoff can be maintained for a period of 168 hours without opening. General note: It is advised that TCOs are not exposed to continuous operating temperatures in excess of more than T _f -25°C.
T _m	Maximum Overshoot Temperature: The maximum temperature at which the thermal cutoff, having changed its state of conductivity, can be maintained at twice rated voltage for a specified period of time, during which its mechanical and electrical properties will not be affected.

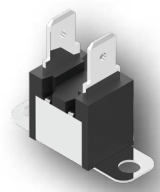
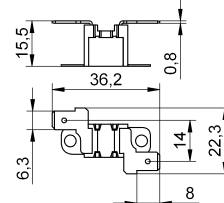
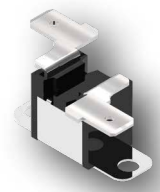
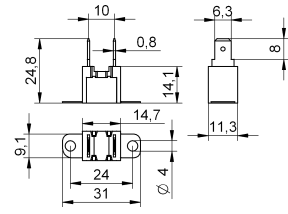
HDMV, HDMH 15A		T_f (Tolerance +0 / -10°C)	type	T_h	T_m	approvals	
	HDMV		78	DM	62	250	UL, cUL
			90	DM	68	250	UL, cUL
			99	DM	83	250	UL, cUL
			110	DM	86	250	UL, cUL
			120	DM	96	250	UL, cUL, VDE
	HDMH		130	DM	112	250	UL, cUL
			140	DM	125	250	UL, cUL
			150	DM	135	250	UL, cUL, VDE
			170	DM	145	250	UL, cUL
			182	DM	163	250	UL, cUL
			190	DM	170	250	UL, cUL

Notes for handling of parts

Bending leads

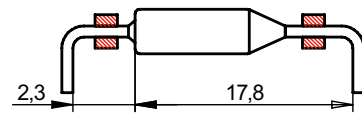
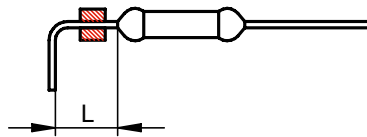
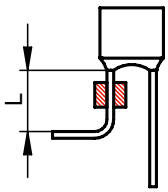

for wire up to \varnothing 1mm

$L \geq 3$ mm

for wire $> \varnothing$ 1mm

$L \geq 5$ mm

Bending radius in general

$R \geq 1$ mm

Soldering leads

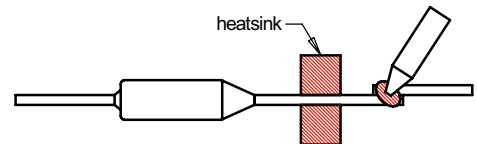
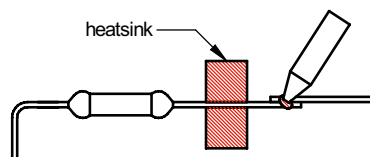
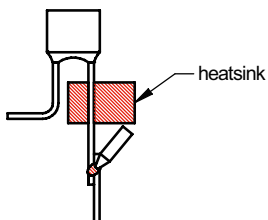

Microtherm GmbH

Taschenwaldstraße 3

75181 Pforzheim

Deutschland

Tel.: +49 7231 787-0

Fax: +49 7231 787-155

info@microtherm.de

www.microtherm.de



MICROTHERM
sentronic